

Installation Guide

Solid Prefinished Hardwood Floors



Please read all instructions carefully before installation. Improper installation may void the warranty.

PRODUCT USE

Recommended Installation

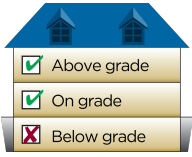

Nailed-Stapled

Mirage Classic products can be installed on and above grade. They may be nailed down with cleats or staples over wooden subfloor, using specially designed hardwood floor nailer. Mirage **does not recommend installation** of Mirage Classic floor over radiant-heated subfloor.

INSTALLER AND OWNER RESPONSIBILITY

Prior to installation, the installer and owner must ensure that the work environment and subfloors meet or even exceed minimal specifications listed in this installation guide.

Standard trade practice allows for up to a 5% margin of error for natural imperfections and manufacturing defects. Prior to installation, the installer and owner should conduct a final inspection of grade, color, manufacturing and finish quality of boards to ensure that the floor conforms to purchased product.

Once installed, every board is considered as having been accepted by installer and owner, even if owner is absent at time of installation. When ordering hardwood flooring, it is recommended to add to the square footage needed an allowance for cutting waste.

WARRANTY

Structural lifetime warranty

Finish warranty

Relative Humidity

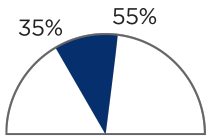

STRUCTURE

STRUCTURAL LIFETIME LIMITED WARRANTY

ALL OUR FLOORS COME WITH A STRUCTURAL LIFETIME LIMITED WARRANTY.

DURAMATT
nanolinx HD

35-YEAR WARRANTY

ON FINISH WEAR-THROUGH FOR RESIDENTIAL APPLICATIONS.

3-YEAR WARRANTY

AGAINST WEAR OF FINISH FOR LIGHT COMMERCIAL APPLICATIONS.

Surface wear must be readily visible and cover at least ten percent (10%) of the total flooring surface area.

Disclaimer

- The nature of Character grade flooring explains the appearance of certain characteristics visible at time of purchase or developing over time, including pronounced color variations, open and closed knots, mineral streaks, cracks, surface holes, and other character or milling marks are part and parcel of this effect.
- Some distinctive marks may become prominent over time due to changes in the environment.

For more information on the warranty or for information on floor care prevention, consult the [Mirage Warranty Certificate](#) and the [Mirage's Residential Maintenance](#) on our website miragefloors.com. In the event of a discrepancy between the information in the Installation Guide and the Mirage Warranty Certificate, the latter shall prevail.

MIRAGE*, Technical Service
1255, 98th Street, Saint-Georges (Quebec) Canada G5Y 8J5
Tel.: 418-227-1181 - 800-463-1303 - Fax: 418-227-1188
 Or by email: technical@miragefloors.com



* MIRAGE, our renewed corporate brand, embodies the quality and care found in our prestigious brands such as Mirage Hardwood Floors and Vintage Hardwood Floors. Our legal entity is called Boa-Franc G.P.

RECOMMENDED TOOLS, MATERIAL AND ACCESSORIES

- Vacuum cleaner or broom
- Scraper
- Leveling bar
- Level
- Leveling compound (optional)
- #20 grit sandpaper (optional)
- Wood and/or concrete moisture meter
- Miter saw
- Handsaw
- Security glasses
- Dust mask (using a miter saw)
- Claw hammer
- Nail punch
- Pry bar
- Square 16" x 24"
- Measuring tape
- Chalk line
- Reversing tongues (optional)
- Repair kit
- *KLEAN by mirage* (maintenance kit)

**NAILED DOWN/STAPLED DOWN INSTALLATION**

- Nailers and staplers.
 - Minimum 1-3/4" (44 mm) nails or staples.
- *Staples or nails length depends on the stapler or nailer selected for the installation.
- Power drill and 3/32" (2 mm) bit.
- Finishing nails 2" (50 mm) or 2-1/2" (63 mm).
- Flooring screws.
- #15 black felt paper (or equivalent).

For more information, refer to the [Technical Newsletter #30](#) at miragefloors.com in the Guide and Support section. Prefinished accessories such as reducers, stair nosings, etc. are available from your Mirage Authorized dealer.

Note: MIRAGE cannot be held responsible for any floor damage resulting from use of inadequate tools.

MANUTENTION AND ACCLIMATIZATION

Prefinished hardwood floor installation **requires a little more time and precaution than unfinished flooring**; handle with care to avoid board surface, component and finish damage.

PRE-INSTALLATION CHECK LIST**Basic requirements**

- Hardwood floor installation should be the very last step of any construction or renovation project.
- Prior to installation, heating system must be in operation, and room temperature must have been maintained at $\pm 72^\circ\text{F}$ ($\pm 22^\circ\text{C}$) for at least one week.
- To avoid any moisture-related damages, subfloor must be dry and basement well ventilated.
- **Relative humidity must be maintained around 45%** at all times.

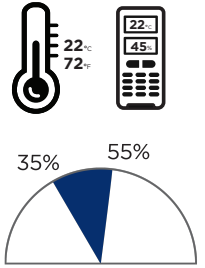
**Subfloor moisture level check**

Wooden subfloor: Wooden subfloor moisture reading must not exceed 12% and differential between boards and subfloor must be less than 4 %. Wood moisture meters are available from your Mirage Authorized dealer. If moisture reading is too high, postpone installation, find moisture source and correct it if needed, raise heat and increase ventilation until proper conditions are met.

**Material Acclimatization**

Keep boxes of wood in room where flooring is to be installed for at least 24 hours before installation. This allows the wood to acclimatize to the recommended indoor conditions.

Owner and installer are solely and jointly responsible for pre-installation subfloor moisture level check and must ensure that all conditions and/or specifications listed in this guide have been thoroughly met prior to installation of hardwood floor.

SUBFLOOR PREPARATION

- Installation requires minimum 5/8" (16 mm) plywood, or 23/32" (18 mm) OSB chipboard subfloor, if installed over 16" (400 mm) center-to-center joist sub-structure.
- **Sound:** Wooden subfloor must be securely screwed down to joists to prevent any movement or squeaks. Thoroughly inspect and replace existing floor or subfloor that shows evidence of water damage or structural weakness. Snow and rain during construction could affect negatively some properties especially on OSB.
- **Flat:** Subfloor surface must be flat and maximum tolerance is 3/16" (5 mm) per 10' (3 m). If necessary, flatten down any irregularities, using #20 grit sandpaper or correct uneven spots.
- **Dry:** Subfloor must be dry and within moisture recommended specs.
- **Clean:** Vacuum and free subfloor from any debris or obstacles such as cleats, nail heads, dried glue or any other material.

PREPARATION

- Sketch installation to avoid surprises
 - Decide starting point or wall.
 - Decide layout angle; 90° or 45° installation to joists is recommended.
- Remove any baseboard, doorsill and old floor covering if necessary.
- Trim bottom of the doorstop with saw to insert boards underneath.
- Lay felt paper (or equivalent) on the entire floor surface.
- To enhance the floor's look, lay out the floor boards throughout the room in the same way they will be installed in order to ensure a good mix of colors and nuances of tone. Remove or relocate any boards you do not want. Start by selecting the boards that will best go with the transition moldings.



GLUED DOWN INSTALLATION INSTRUCTIONS (Illustration #1 & #2)

Wear security equipment and maintain a safe environment at all times.

Step 1: Starting point

- Using a chalk line, trace guideline **A** parallel to starting wall and perpendicular to adjacent one. To trace guideline, add 3/4" (19 mm) to board width to account for expansion gap **B** and board tongue. For example, if installing 3-1/4" (83 mm) boards, trace guideline at 4" (102 mm) from starting wall.

Step 2: Board laying

- It is very important that installation be started straight and square.
- Carefully select boards, remove imperfections and save boards with high color variation for hidden places.
- Align first board tongue side with starting line, **A** grooved side facing starting wall; leave 1/4" (6 mm) gap from right side wall **E** which is perpendicular to starting line. Drill and nail board vertically **C** as close to wall as possible to hide nail heads when baseboards and quarter rounds **D** are in place. Install subsequent boards from right to left until ready to trim row end board.
- To minimize trim waste, select board long enough for row end, so that remaining trimmed end may be used to start subsequent row. Leave 1/4" (6 mm) gap at end of each row **E**.
- First board of second row must be at least 6" (150 mm) shorter or longer than that of first row. Cross joints must be staggered by at least 6" (150 mm) from one row to the next. Avoid lining the joints up or having them follow too regular a pattern (illustration #3).
- Since wall proximity prohibits use of nailer, use finishing nails approximately every 4" (100 mm) alongside tongue **F** for first few rows, and punch nail heads down.
- Subsequent rows must be installed the same way, using the nailer (see nailer tips at side); nail or staple boards every 6 to 8" (150 to 200 mm), and must have a fastener (nail or staple) between 2 to 3" (50 to 75 mm) on the ends of each boards.
- Because of wall proximity, installation of last 4 or 5 rows is identical to installation of first few rows. You might have to rip-saw last row of boards to leave required 1/2" (12 mm) gap **B** alongside finishing wall.

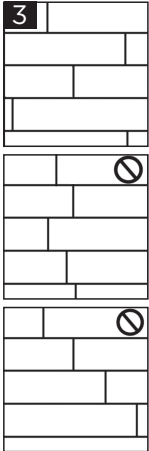

Notes:

- Extremely precise board milling may require use of tapping block for better tongue and groove fit.

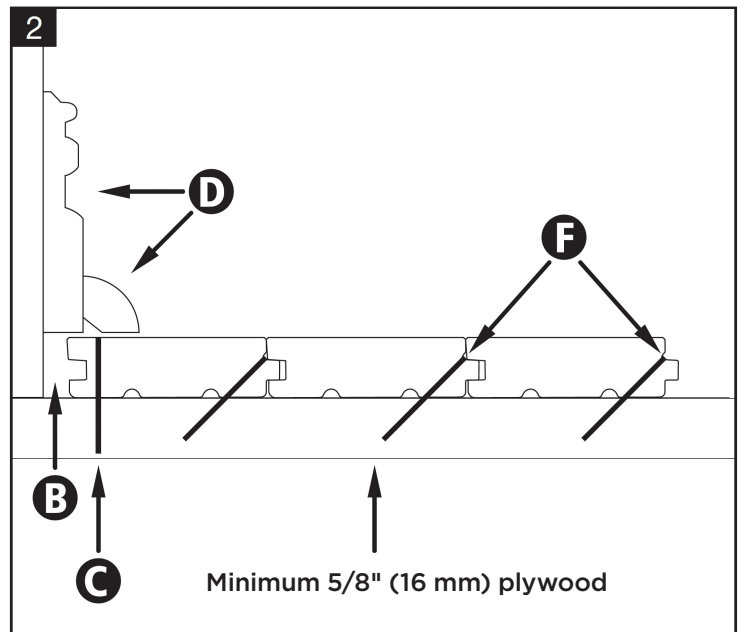
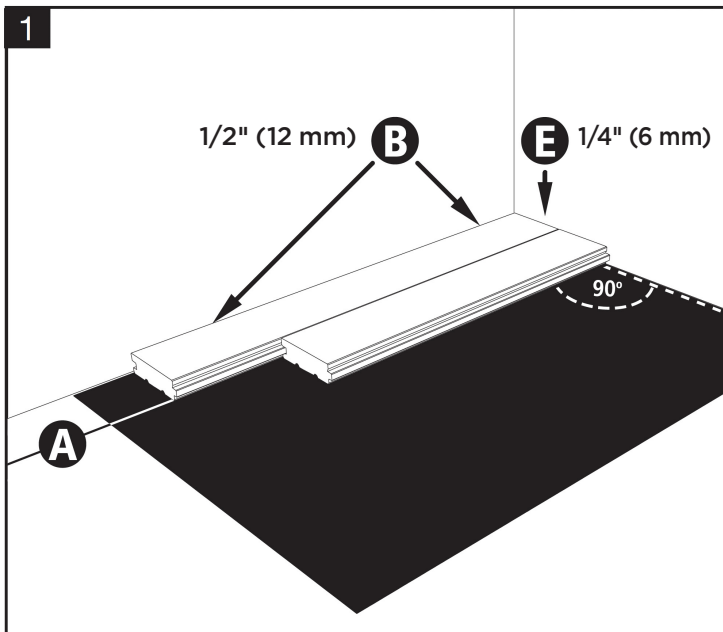

- **Step 3: Accessories installation**

- If applicable, install transition moldings, stair nosings and reducers.
- If applicable, reinstall baseboards and quarter rounds, making sure to nail them only to walls and not to floor (to allow free floor movement).

- **Step 4: Post-installation**

- Set a few boards aside in case of future repairs.
- When installation is completed, vacuum floor thoroughly, spray light mist of *Klean by mirage* on the microfiber mop cover and clean floor.



NAILER TIPS

Warning

To avoid damaging boards during installation:

- Ensure that nailer base plate remains clean and free from nicks at all times.
- When nailer is not being used, place on piece of plywood or cardboard, but never directly onto floor.
- Ensure that nailer base sits flat on floor and plumb against tongue before nailing board down.
- **Check base plate condition and proper operation of nailer regularly.**
- Set and check air pressure regularly, keeping in mind that different hardwood species or subfloor types require specific air pressure settings.